

NM-R SERIES

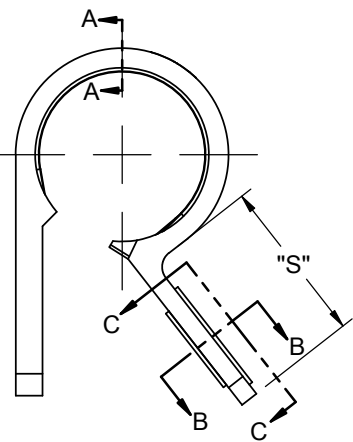

OPENED POSITION (FREE)

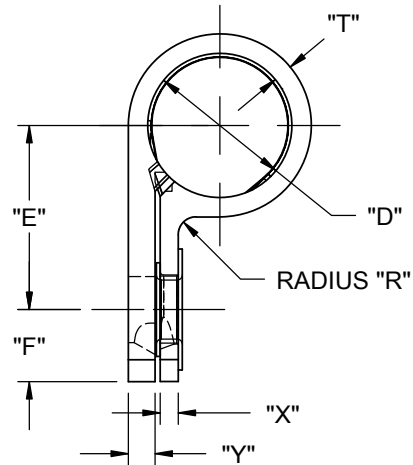
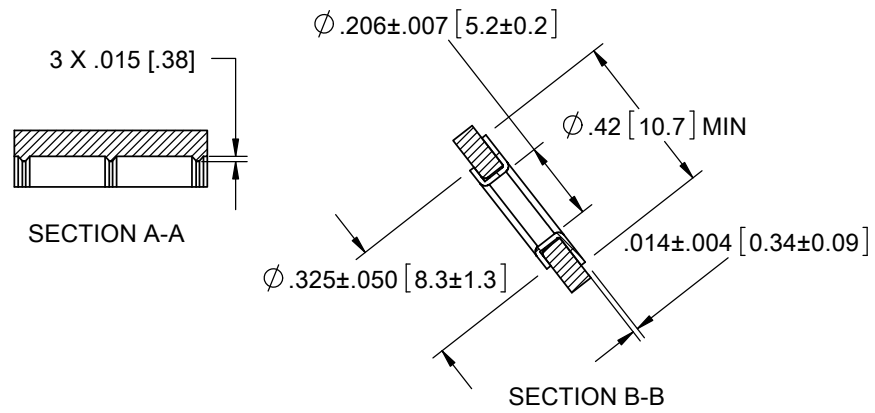
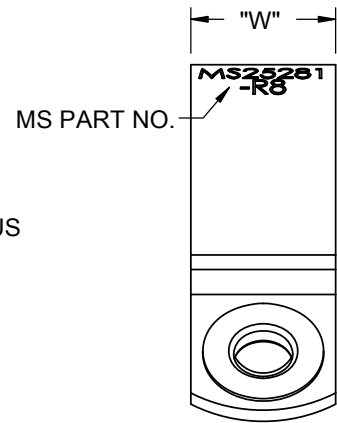
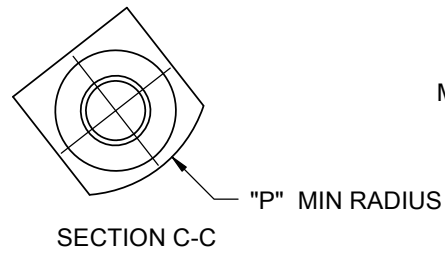

CLOSED POSITION R SERIES (INSTALLED)

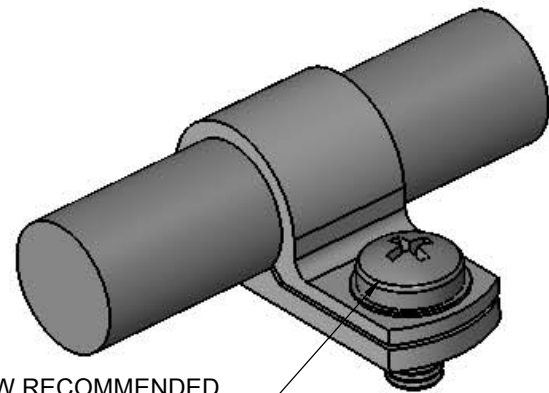

#10 or M5 SCREW RECOMMENDED.
SCREW NOT SUPPLIED.



REV.	DESCRIPTION	ENGR.	DATE
G	ADDED NM-6-F6, SEE CO 200637	SK	03/15/11
F	ADDED NM-24-R24, SEE CO 200631	SK	03/04/11
E	ADDED NEW PARTS, SEE CO 200623	SK	02/04/2011
D	ADDED NEW PARTS, SEE CO 200622	SK	01/28/11
C	ADDED NEW PARTS, SEE CO 200606	SK	12.02.10
B	ADDED NEW PARTS, SEE CO 200590	SK	11/10/2010
A	RELEASED FOR PRODUCTION	SK	09/30/2009

TITLE: SUPPORT CLAMP WITH EYELET		DWG IN IN [MM]			
CREATED USING SOLIDWORKS	FILE #: NM	DWN: D.J.Z.	APP: D.J.Z.	FINAL	
TOLERANCES UNLESS NOTED .XX=±.010 .XXX=±.005 FRAC.=±1/64 ANG.=±1°	SHEET: 1 OF 3	SHEET SIZE: B	DT: 09/15/2009	CHKD: B.R.	PART #
	RE: RICHCO INC.		RICHCO, INC.	WWW.RICHCO-INC.COM	SEE TABLE
					PRINT TYPE CA

NM-R SERIES												
RICHCO PART NUMBER	MS PART NUMBER	CABLE BUNDLE DIAMETER REF	"D" ±.020 [5]	"E" ±.025[6]	"F"	"P" MIN RADIUS	"R"±.005	"S"	"T" ±.017	"W"	"X"	"Y"
NM-3-R3	MS25281-R3	3/16 [4.8]	.188 [4.8]	.485 [12.3]	.250±.010 [6.4]	.250 [6.4]	.062 [1.57]	.540±.010 [13.7]	.057 [1.4]	.503±.007 [12.8]	.065 [1.7]	.080±.020 [2]
NM-4-R4	MS25281-R4	1/4 [6.4]	.250 [6.4]	.510 [13]								.093±.007 [2.4]
NM-5-R5	MS25281-R5	5/16 [7.9]	.312 [7.9]	.546 [13.9]								
NM-6-R6	MS25281-R6	3/8 [9.52]	.375 [9.5]	.578 [14.7]								
NM-7-R7	MS25281-R7	7/16 [11.1]	.438 [11.1]	.608 [15.4]								
NM-8-R8	MS25281-R8	1/2 [12.7]	.500 [12.7]	.639 [16.2]								
NM-10-R10	MS25281-R10	5/8 [15.9]	.625 [15.9]	.706 [17.9]	.285±.045 [7.2]	.300 [7.6]	.109 [2.77]	.605±.010 [15.37]	.068 [1.7]	.553±.057 [14.05]	.065 [1.7]	.108±.022 [2.74]
NM-11-R11	MS25281-R11	11/16 [17.5]	.688 [17.5]	.785 [19.9]								
NM-12-R12	MS25281-R12	3/4 [19.05]	.750 [19.05]	.816 [20.7]								
NM-13-R13	MS25281-R13	13/16 [20.6]	.812 [20.6]	.827 [21]								
NM-14-R14	MS25281-R14	7/8 [22.2]	.875 [22.2]	.878 [22.3]								
NM-16-R16	MS25281-R16	1.000 [25.4]	1.000 [25.4]	.941 [23.9]								
NM-18-R18	MS25281-R18	1-1/8 [28.6]	1.125 [28.6]	.983 [25]								
NM-20-R20	MS25281-R20	1-1/4 [31.75]	1.250 [31.75]	1.066 [27.1]								
NM-22-R22	MS25281-R22	1-3/8 [34.9]	1.375 [34.9]	1.110 [28.2]								
NM-22-R24	MS25281-R24	1-1/2 [38.1]	1.500 [38.1]	1.17 [29.7]								
NM-26-R26	MS25281-R26	1-5/8 [41.3]	1.625 [41.3]	1.250 [31.75]	.120±.040 [3]	.553±.057 [14.05]	.090 ^{+0.040} _{-.005} [2.3]	.125±.005 [3.2]				
NM-28-R28	MS25281-R28	1-3/4 [44.45]	1.750 [44.45]	1.300 [33]								

- NOTES:
1. MATERIALS:
THERMOPLASTIC: HEAT STABILIZED NYLON 6/6 UL94 V-2 (RMS-164), CONFORMS TO MIL-M-20693 / ASTM D-4066
EYELET: ALUMINUM (RMS-82), ANODIZED IN ACCORDANCE WITH MIL-A-8625.
2. COLOR: LIGHT GREEN
3. PARTS CONFORM TO SAE AS23190 / MS25281
4. ALTERNATE UNITS [] ARE ROUNDED AND FOR REFERENCE ONLY

REV.	DESCRIPTION	ENGR.	DATE

TITLE: SUPPORT CLAMP WITH EYELET				 		DWG IN IN [MM]	
CREATED USING SOLIDWORKS	FILE #: NM	DWN: D.J.Z.	APP: D.J.Z.	FINAL			
TOLERANCES UNLESS NOTED .XX=±.010 .XXX=±.005 FRAC.=±1/64 ANG.=±1°	SHEET: 2 OF 3	SHEET SIZE: B	DT: 09/15/2009	CHKD: B.R.	PART #	PRINT TYPE	
	RE: RICHCO INC.		RICHCO, INC. WWW.RICHCO-INC.COM		SEE TABLE	CA	



NM-F SERIES

RICHCO PART NUMBER	MS PART NUMBER	CABLE BUNDLE DIAMETER REF	"D" ±.020 [.5]	"E" ±.025[.6]	"F"	"P" MIN RADIUS	"S"	"T" -.010 -.005	"W"	"X" ^{-.010} _{-.005}	"Y" ^{-.010} _{-.005}
NM-3-F3	MS25281-F3	3/16 [4.8]	.187 [4.8]	.498 [12.6]	.250±.015 [6.4]	.250 [6.4]	.489±.015 [12.4]	.040 [1.02]	.500±.015 [12.7]	.065 [1.65]	.065 [1.65]
NM-6-F6	MS25281-F6	3/8 [9.5]	.375 [9.5]	.592 [15]				.062 [1.6]			.095 [2.4]
NM-10-F10	MS25281-F10	5/8 [15.9]	.625 [15.9]	.783 [19.9]	.300±.010 [7.6]	.300 [7.6]	.520±.015 [13.2]	.073 [1.85]	.600±.015 [15.2]	.075±.010 [1.9]	.125±.010 [3.2]

NOTES:

1. MATERIALS:
THERMOPLASTIC: HEAT STABILIZED NYLON 6/6 UL94 V-2 (RMS-164), CONFORMS TO MIL-M-20693 / ASTM D-4066
EYELET: ALUMINUM (RMS-82), ANODIZED IN ACCORDANCE WITH MIL-A-8625.
2. COLOR: LIGHT GREEN
3. PARTS CONFORM TO SAE AS23190 / MS25281
4. ALTERNATE UNITS [] ARE ROUNDED AND FOR REFERENCE ONLY

REV.	DESCRIPTION	ENGR.	DATE

TITLE: SUPPORT CLAMP WITH EYELET						DWG IN IN [MM]	
CREATED USING SOLIDWORKS	FILE #: NM	DWN: D.J.Z.	APP: D.J.Z.	FINAL			
TOLERANCES UNLESS NOTED .XX=±.010 .XXX=±.005 FRAC.=±1/64 ANG.=±1°	SHEET: 3 OF 3	SHEET SIZE: B	DT: 09/15/2009	CHKD: B.R.	PART #	PRINT TYPE	
RE: RICHCO INC. --	RICHCO, INC. WWW.RICHCO-INC.COM		SEE TABLE		CA		